



# Modular Cooking Range Line 900XP Two Wells Electric Fryer 23 liter

ITEM # \_\_\_\_\_

MODEL # \_\_\_\_\_

NAME # \_\_\_\_\_

SIS # \_\_\_\_\_

AIA # \_\_\_\_\_



- 391385 (E9KKG0BAMEA)** 23+23-lt electric Fryer with 2 "V" shaped wells (external heating elements), 4 half size baskets and lids included
- 391338 (E9KKG0DBAMEA)** 23+23-lt electric Fryer with 2 "V" shaped wells (external heating elements), 4 half size baskets and lids included

## Short Form Specification

Item No. \_\_\_\_\_

High efficiency external infrared heating elements (36kW) with innovative deflectors attached to the outside of the well. Deep drawn V-Shaped wells. Oil drains through a tap into a container positioned under the wells. Height adjustable feet in stainless steel. Exterior panels in stainless steel. Worktop in 20/10, stainless steel. Right-angled side edges eliminate gaps and possible dirt traps between units.

## Main Features

- Deep drawn V-Shaped wells.
- Interior of wells with seamlessly laser-welded corners for ease of cleaning.
- External infrared heating elements with innovative deflectors applied to the well for ease of cleaning of the internal well and safe operations.
- Thermostatic regulation of oil temperature up to a maximum of 185 °C.
- Overheat protection thermostat as standard on all units.
- All major compartments located in front of unit for ease of maintenance.
- The special design of the control knob system guarantees against water infiltration.
- Supplied as standard with 4 half size baskets and 1 right and left side doors for cupboard.
- Optional portable oil quality monitoring tool (code 9B8081) for efficient oil management.

## Construction

- Unit is 930 mm deep to give a larger working surface area.
- All exterior panels in Stainless Steel with Scotch Brite finishing.
- Model has right-angled side edges to allow flush fitting joints between units, eliminating gaps and possible dirt traps.
- Unit delivered with four 50 mm legs in stainless steel as standard.
- IPX5 water resistance certification.

## Sustainability

- This model is compliant with Swiss Energy Efficiency Ordinance (730.02).



APPROVAL: \_\_\_\_\_



**Included Accessories**

- 2 of Door for open base cupboard PNC 206350
- 2 of 2 half size baskets for 15lt OptiOil and 18/23lt fryers PNC 927223

**Optional Accessories**

- Stainless steel oil filter for 18/23lt fryers (only for 391338) PNC 200086
- Junction sealing kit (only for 391338) PNC 206086
- Kit 4 wheels - 2 swivelling with brake - it is mandatory to install Base support and wheels (only for 391338) PNC 206135
- Flanged feet kit (only for 391338) PNC 206136
- Pair of side kicking strips (not for refr-freezer base) (only for 391338) PNC 206180
- Hygienic lid for 23lt fryers (only for 391338) PNC 206201
- Frontal kicking strip for 23lt fryers in two parts (only for 391338) PNC 206203
- Extension pipe for oil drainage for fryers (only for 391338) PNC 206209
- Chimney upstand, 800mm (only for 391338) PNC 206304
- Door for open base cupboard (only for 391338) PNC 206350
- Base support for feet or wheels (lateral) for 23lt fryers, pasta cookers and refrigerated bases (900XP) (only for 391338) PNC 206372
- Chimney grid net, 400mm (700XP/900) (only for 391338) PNC 206400
- 2 side covering panels for free standing appliances (only for 391338) PNC 216134
- Sediment collection tray for 23-litre fryer (to be put in the well) (only for 391338) PNC 921023
- 2 half size baskets for 15lt OptiOil and 18/23lt fryers (only for 391338) PNC 927223
- 1 full size basket for 15lt OptiOil and 18/23lt fryers (only for 391338) PNC 927226
- Unclogging rod for 23lt fryers drainage pipe (only for 391338) PNC 927227
- Deflector for floured products for 23lt fryers (only for 391338) PNC 960645

Front

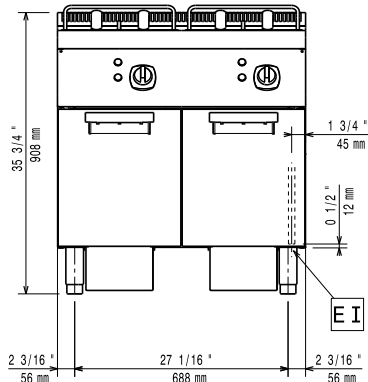

Side

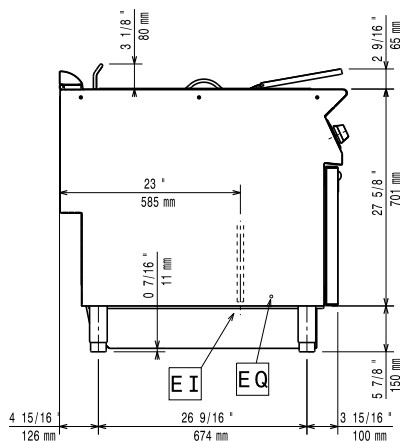

EI = Electrical inlet (power)  
EQ = Equipotential screw

Top

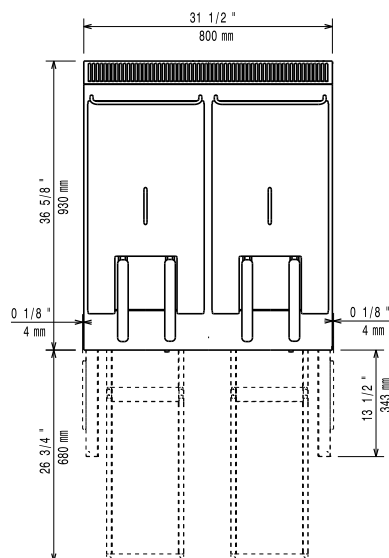

## Electric

### Supply voltage:

391385 (E9KKGOBAMEA) 415-430 V/3N ph/50-60 Hz  
380-400 V/3N ph/50-60 Hz

391338 (E9KKGDBAMEA)

### Total Watts:

391385 (E9KKGOBAMEA) 34.4 kW  
391338 (E9KKGDBAMEA) 36 kW

## Key Information:

If appliance is set up or next to or against temperature sensitive furniture or similar, a safety gap of approximately 150 mm should be maintained or some form of heat insulation fitted.

### Usable well dimensions

(width): 340 mm

### Usable well dimensions

(height): 575 mm

### Usable well dimensions

(depth): 400 mm

### Well capacity:

21 lt MIN; 23 lt MAX

### Performance\*:

391385 (E9KKGOBAMEA) 70.8 kg/hr

391338 (E9KKGDBAMEA) 75 kg/hr

### Thermostat Range:

105 °C MIN; 185 °C MAX

### Net weight:

115 kg

### Shipping weight:

125 kg

### Shipping height:

1080 mm

### Shipping width:

1020 mm

### Shipping depth:

391385 (E9KKGOBAMEA) 860 mm

391338 (E9KKGDBAMEA) 880 mm

### Shipping volume:

391385 (E9KKGOBAMEA) 0.95 m<sup>3</sup>

391338 (E9KKGDBAMEA) 0.97 m<sup>3</sup>

### \*Based on:

ASTM F1361-Deep fat fryers

### Certification group:

EFE92M23